

Dawsongroup | tcs

SMARTER
ASSET
STRATEGY





I2I Who We Are

I3I Temp°store 80 and Temp°store 100

I4I Main Features and Benefits

I5I Temp°store 100 Structure Footprint

Who We Are

Dawsongroup plc is a group of companies specialising in the supply of commercial assets. The group has grown from a core truck and trailer rental product to cover nine distinct asset groups, built on innovation and a commitment to service excellence.

Dawsongroup | TCS specialises in providing temperature control solutions for a broad range of industry sectors, including food and beverage, pharmaceutical, logistics, research and development, environmental and more.

Our mission is to work with you, not just for you. Our Smarter Asset Strategy enables you to grow your business, improve output and reduce energy costs with complete flexibility in a changing market. We focus on sustainability and establishing long-term relationships with clients through our continued high standard of customer support and service.

We deliver a wide range of solutions, from cold storage facilities and high-capacity blast freezers to controlled defrost and tempering units, from stand-alone units to modular complexes, and from robotics and automation to cross docks and test chambers.

We were proud to receive the Queen's Award for Enterprise for Innovation 2022 for our unique Temp°store design, which is ideal for providing cold storage capability quickly and efficiently in remote locations and disaster zones.

Whichever industry your business is in, Dawsongroup's Smarter Asset Strategy is the solution you never knew you needed.

Temp°store 80 and Temp°store 100

Dawsongroup | TCS innovative inflatable Temp°store 80 and 100 structures are extremely versatile and ideal for any purpose. They are simple, robust, and quick to install, as they do not need the groundworks or construction time that traditional temporary buildings need. As well as being modular, they are available in various widths and lengths to meet any requirements, and the inflatable walls provide greater sound and temperature insulation.

Temp°store 80 and 100 structures can be combined with air handling units from Dawsongroup Process and Climate Control and a specially designed insulated liner to maintain the internal temperature to chilled storage.



Main Features and Benefits

Faster Deployment

Deployable in one day, minimizing disruption to your business

Scalability

Flexible and scalable, from stand-alone single units to multiple modular units

Durability

Highly durable and fire retardant with a material tensile strength of 5.5 ton per metre

Reduced HVAC Costs

Natural insulation provided by air-filled walls and roof

Comfort

Inflatable structures are less prone to condensation and damp

Flexible Temperature

Available in ambient temperatures with the option to combine with Dawsongroup Process and Climate Control's air handling units; an insulated liner can be added for chilled storage to 4°C

Door Configuration

Door configuration to suit, with optional roller shutter doors, or open entrance

Internal Dimensions

Available in 10.0m and 12.5m spans. Multiple modules can be joined to provide any length in 10.0m increments. Internal height from 3.8m to 7.2m

External Dimensions

12m or 15m span. Any length in 10.0m increments. Maximum external height 7.7m or 8.5m

Inflation System

Side channel blowers with automatic pressure control units. Multiple fail-safes and in-built redundancy. Electrically actuated pressure relief valves with mechanical backups

Suitability

Ambient or chilled; temporary warehouse, storage, packing, shelter, event venue and more



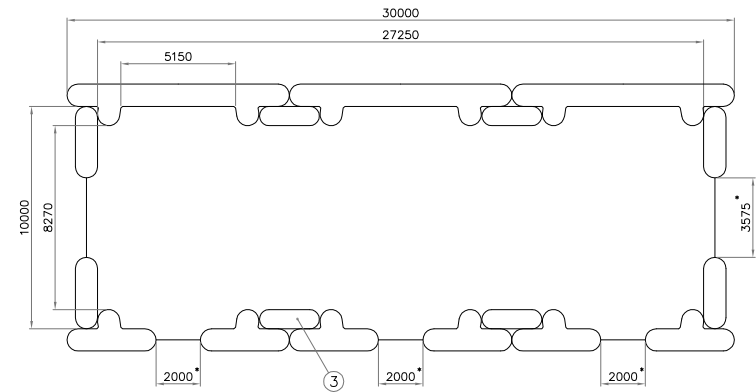
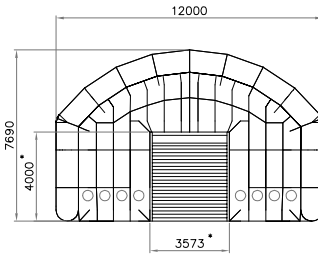
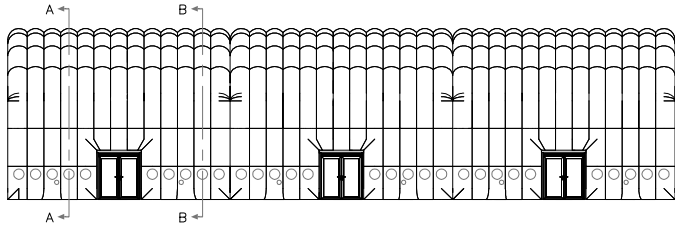
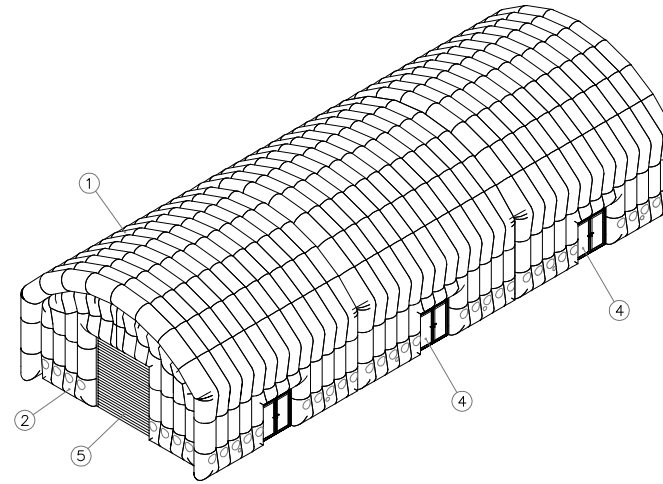
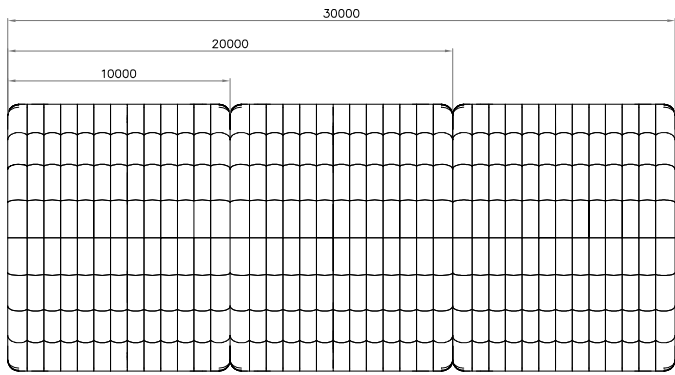

* SIZE OF APERTURE IN INFLATABLE STRUCTURE. USABLE DIMENSION WILL BE REDUCED DEPENDING UPON THE TYPE OF DOORWAY FITTED

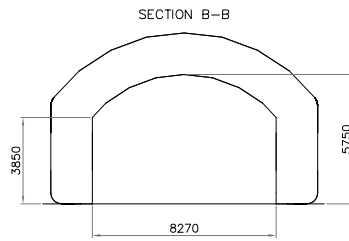
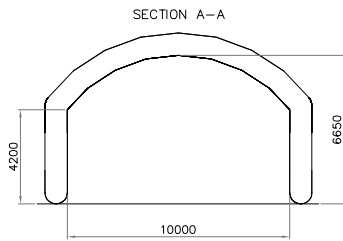

Temp°store 80 Structure Footprint

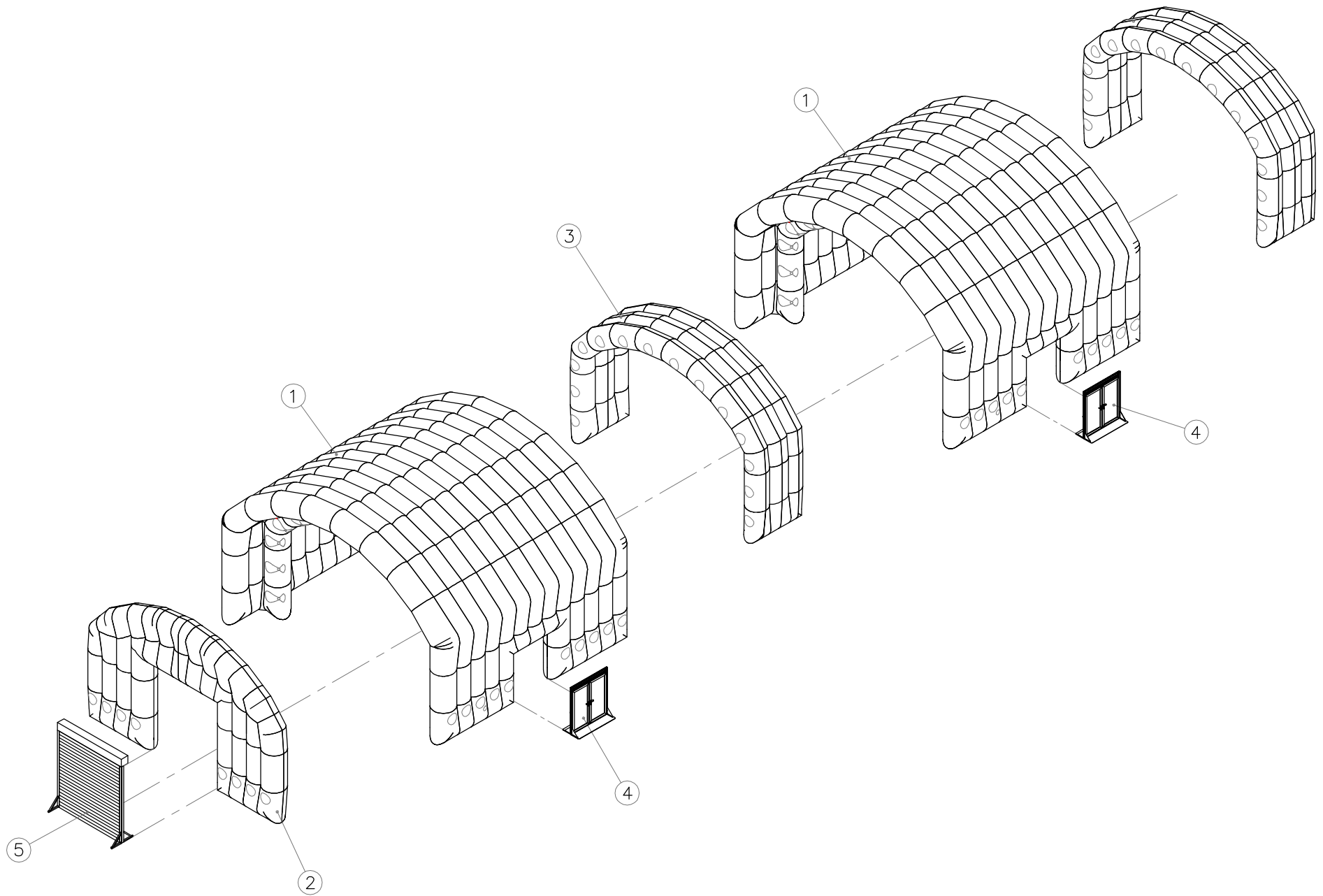

Structure can be increased or decreased in length in multiples of 10.0m



+44 (0) 1623 516666

info@dgpcs.co.uk